

VU01

Ventilation unit for SR20 and SR22 pyranometers and IR20 pyrgeometers

VU01 is a high-quality ventilation unit for use with pyranometers and pyrgeometers. Its purpose is to improve the dependability of the measurement. Measurement accuracy improves because offsets are reduced. Reliability benefits from prevention of dew and frost formation and quick evaporation and sublimation of water and snow. ISO/TR 9901 "Solar Energy - Field Pyranometers - Recommended practice for use" recommends use of ventilators where high accuracy and reliability are required.



Figure 1 VU01 ventilation unit with pyranometer SR20

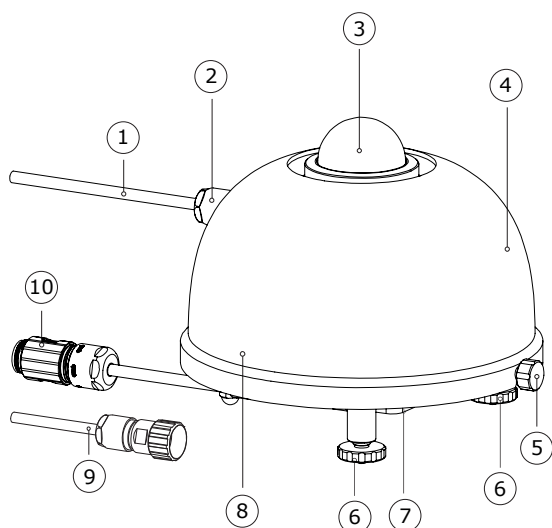

Figure 2 overview of VU01 with SR20:
 (1) SR20 cable, (2) SR20 connector, (3) SR20 dome,
 (4) VU01 cover, (5) fixation of cover, (6) levelling feet,
 (7) VU01 filter retainer, (8) VU01 ventilator, heaters
 and filter replacement system (below cover), (9) VU01
 cable and cable connector, (10) VU01 connector

Introduction

Ventilation unit VU01 may be used in combination with Hukseflux' SR20, SR22 and SR25 secondary standard pyranometers and IR20 and IR20WS research grade pyrgeometers. VU01 provides an airflow over the instrument body and dome and has two heaters on board to heat the air. The use of heating (5 W or 10 W) is optional. The VU01 ventilation unit runs on 12 VDC voltage.

Improved measurement dependability

Ventilation promotes thermal equilibrium between all components of radiometers, and thereby reduces zero offsets. Dew and frost formation is prevented. Additional heating will promote evaporation of water droplets and sublimation of snow. It should be noted that heating in combination with pyranometers will lead to increased thermal offsets, so heating is only recommended if necessary.

Maintenance / cleaning

Ventilation is typically used with high accuracy measurement requirements. In such cases the need for a high level of instrument maintenance and dome cleaning still exists; evaporating droplets of water might leave stains on the instrument domes. The bottom of VU01 provides access to the removable dust filter.

Operation

Using VU01 is easy. The ventilator is generally used continuously; the heater is typically controlled by the datalogger. ISO/TR 9901 "Solar Energy - Field Pyranometers - Recommended practice for use" recommends use of ventilators where high accuracy and reliability are required. More details can be found in paragraph 5.2.2 and annex A. The Baseline Surface Radiation Network, BSRN, recommends ventilation for radiometers in its BSRN operations manual v2.1.

VU01 design

VU01 is designed, using high-quality materials, in agreement with the recommendations of ISO/TR 9901 and BSRN. The footprint of VU01 is small, which prevents accumulation of snow. The ventilator power is relatively high in order to increase the airflow. The heaters should be activated using external relays. A fan status signal (high / low) may be used by the user to monitor rotation of the fan.

Suggested use

- PV system performance monitoring
- scientific meteorological observations
- extreme climates (tropical / polar)

Choosing the right instrument

Pyranometers are subject to classification in three classes according to ISO 9060. Our pyranometer selection guide assists you in choosing the right instrument. Whatever your application is: Hukseflux offers the highest accuracy in every class at the most attractive price level.

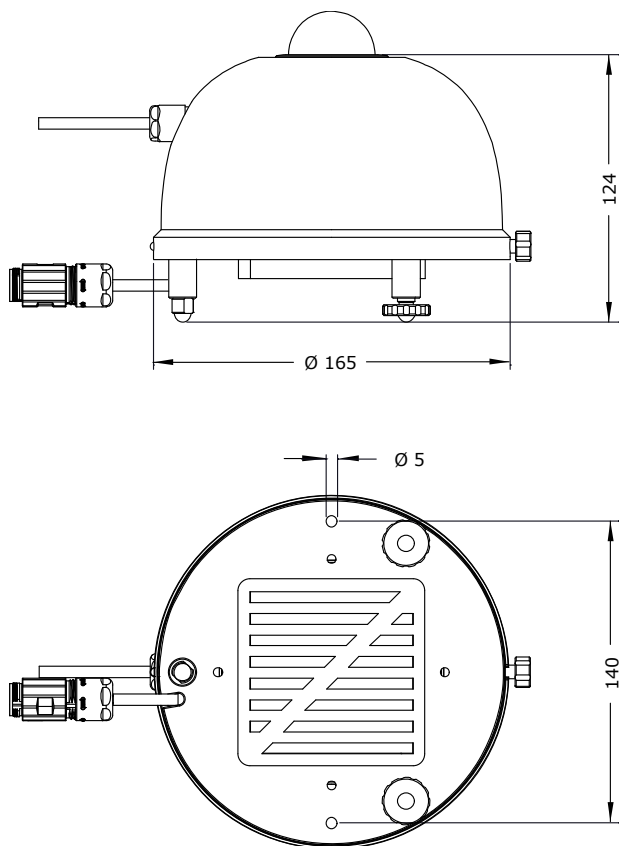

Figure 3 VU01 dimensions in $\times 10^{-3}$ m

VU01 specifications

Compatible instruments	SR20, SR20-D2, SR22, SR25, SR25-D1, IR20, IR20WS
Compliance with standards	ISO/TR 9901 BSRN operations manual
Rated operating power	7.8 W at 12 VDC (unheated)
Rated operating voltage range	10.8 to 13.2 V
Rated operating temperature range	-40 to +70 °C
Fan status signal	high / low (optional use)
Heater	5 and 10 W at 12 VDC (optional use)
Increase of air temperature	0.5 °C at 0 W heating 1.0 °C at 5 W heating 1.5 °C at 10 W heating
Zero offset a SR20 ventilated	2.5 W/m ² at 0 W heating
Offset SR20 by heating	- 2 W/m ² at 5 W heating - 4 W/m ² at 10 W heating
Offset IR20 by heating	0 W/m ² at 5 W heating 0 W/m ² at 10 W heating
Cable resistance	0.3 Ω/m (2 x 0.15 Ω/m)
Voltage drop at 10 W heating power	0.12 V/m
Footprint diameter	0.17 m
Standard cable length	5 m (see options)

Options

- longer cable, in multiples of 5 metres (please note the voltage drop of cabling)
- pack of 5 filters (VU01F)

See also

- SR20, SR20-D2 and SR22 pyranometer
- IR20 and IR20WS research grade pyrgeometer

About Hukseflux

Hukseflux Thermal Sensors offers measurement solutions for the most challenging applications. We design and supply sensors as well as test & measuring systems, and offer related services such as calibration, engineering and consultancy. Our main area of expertise is measurement of heat transfer and thermal quantities such as solar radiation, heat flux and thermal conductivity. Hukseflux is ISO 9001:2008 certified. Hukseflux sensors, systems and services are offered worldwide via our office in Delft, the Netherlands and local distributors.

Interested in this product?
E-mail us at: info@huksefluxusa.com