

SRA01

Second class albedometer

SRA01 albedometer is an instrument that measures global and reflected solar radiation and the solar albedo, or solar reflectance. It is composed of two identical second class pyranometers with thermopile sensors, the upfacing one measuring global solar radiation, the downfacing one measuring reflected solar radiation. SRA01 complies with the latest ISO and WMO standards.



Figure 1 SRA01 second class albedometer

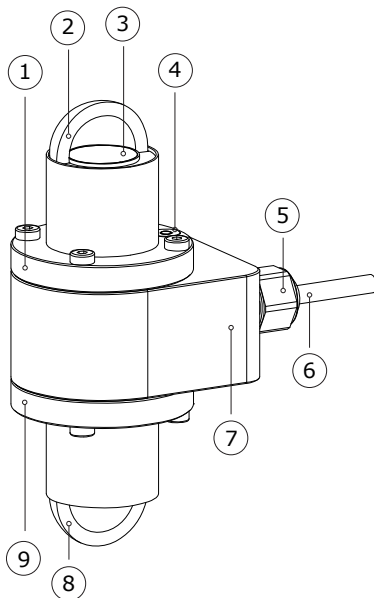

Figure 2 overview of SRA01:
 (1) upfacing pyranometer body, (2) glass dome,
 (3) thermal sensor with black coating, (4) bubble level,
 (5) cable gland, (6) cable, (7) albedometer body, (8)
 glass dome, (9) downfacing pyranometer body

Introduction

Albedo, also called solar reflectance, is defined as the ratio of the reflected to the global radiation. The solar albedo depends on the directional distribution of incoming radiation and on surface properties at ground level. Albedos of typical surfaces range from about 4 % for fresh asphalt, and 15 % for green grass to 90 % for fresh snow.

Using SRA01 is easy. The albedometer is composed of two pyranometers, the upfacing one measuring global solar radiation, the downfacing one measuring reflected solar radiation. The irradiance in W/m^2 in each direction is calculated by dividing the pyranometer output, a small voltage, by the sensitivity. The sensitivity of both pyranometers, model SR01, is provided on the SRA01 product certificate. The working principle and specifications of the pyranometers can be found in the SRA01 manual. SRA01 can be connected directly to commonly used datalogging systems.

Applications

Albedometers are used for general meteorological observations, building physics, roof reflectance studies, climate studies and solar collector testing. A common application is for outdoor solar radiation measurements as part of a meteorological station. This application requires horizontal levelling; a bubble level is included. SRA01 is designed to fit a $\frac{3}{4}$ inch NPS mounting tube.

Uncertainty evaluation

The uncertainty of a measurement under outdoor conditions depends on many factors. Guidelines for uncertainty evaluation according to the "Guide to Expression of Uncertainty in Measurement" (GUM) are found in our manuals. We provide spreadsheets to assist in the process of uncertainty evaluation of your measurement.

SRA01 design

SRA01 consists of two identical pyranometers model SR01, one facing up, one facing down. The albedometer body is designed to fit a 3/4 inch NPS tube for mounting purposes. The cable can be led away through the tube (the tube's recommended outer diameter is $< 28 \times 10^{-3}$ m, the inner diameter $> 20 \times 10^{-3}$ m). Such a mounting tube is not part of the delivery. SRA01 can be ordered with longer cable and optional sun screens.



Figure 3 SRA01 second class albedometer, designed to fit a 3/4 inch NPS mounting tube

Suggested use

- agricultural networks
- general meteorological observations
- building physics, roof reflectance studies

Standards

Applicable instrument-classification standards are ISO 9060 and WMO-No. 8. Calibration is according to ISO 9847 and ASTM G207-11.

See also

- SRA20 secondary standard albedometer for high-accuracy albedo measurement
- alternative instrument: NR01 for solar and longwave radiation balance
- view our complete range of solar sensors

SRA01 specifications

Measurand	global solar radiation and reflected solar radiation
Optional measurand	albedo or solar reflectance
Optional measurand	net solar radiation
Included sensors	2 x identical ISO 9060 second class pyranometer
Mounting	3/4 inch NPS tube (not included)
Calibration uncertainty	$< 1.8 \%$ ($k = 2$)
Calibration traceability	to WRR
Measurement range	0 to 2000 W/m ²
Spectral range	285 to 3000 $\times 10^{-9}$ m
Sensitivity (nominal)	15 $\times 10^{-6}$ V/(W/m ²)
Rated operating temperature range	-40 to +80 °C
Temperature response	$< \pm 3 \%$ (-10 to +40 °C)
Standard cable length	5 m (see options)

Options

- longer cable, in multiples of 5 m, cable lengths above 20 m in multiples of 10 m
- sun screens

About Hukseflux

Hukseflux Thermal Sensors offers measurement solutions for the most challenging applications. We design and supply sensors as well as test & measuring systems, and offer related services such as engineering and consultancy. With our laboratory facilities, we provide testing services including material characterisation and calibration. Our main area of expertise is measurement of heat transfer and thermal quantities such as solar radiation, heat flux and thermal conductivity. Hukseflux is ISO 9001:2008 certified. Hukseflux sensors, systems and services are offered worldwide via our office in Delft, the Netherlands and local distributors.

Interested in this product?
E-mail us at: info@huksefluxusa.com