

## SR25

### Secondary standard pyranometer with sapphire outer dome

*SR25 takes solar radiation measurement to the next level. Using a sapphire outer dome, it has negligible zero offsets. SR25 is heated in order to suppress dew and frost deposition, maintaining its measurement accuracy. When heating SR25, the data availability and accuracy are higher than when ventilating traditional pyranometers. SR25 needs very low power. Patents on the SR25 working principle are pending.*



**Figure 1** SR25 secondary standard pyranometer



**Figure 2** frost deposition: clear difference between SR25 (left), versus a non-heated pyranometer without sapphire dome (right)

### Introduction

SR25 represents the next level in solar radiation measurement. Using a sapphire outer dome, it has negligible zero offsets. SR25 is heated in order to suppress dew and frost deposition, maintaining its high measurement accuracy.

When heating SR25, the data availability and accuracy are higher than when ventilating traditional pyranometers. In addition, SR25 needs very low power; it only consumes 1.5 W compared to the usual 10 W for ventilation. The low thermal offsets make SR25 very suitable for measuring diffuse radiation. Patents on the SR25 working principle are pending. SR25 is available with analogue millivolt output and (as SR25-D1) with digital output - Modbus protocol.

### Best data availability

By keeping the SR25 outer dome free of dew and frost with help of the internal heater, data availability is highly increased over traditional pyranometers, whether these are ventilated or not.

## Best measurement accuracy

SR25 measures the solar radiation received by a plane surface, in  $W/m^2$ , from a  $180^\circ$  field of view angle. SR25 offers the best measurement accuracy: the specification limits of two major sources of measurement uncertainty have been greatly improved over competing pyranometers: "zero offset a" and temperature response.



**Figure 3** SR25 pyranometer with its sun screen removed

## SR25 design

SR25 has a sapphire outer dome, glass inner dome and an internal heater. It employs a state-of-the-art thermopile sensor with black coated surface and an anodised aluminium body. The connector, desiccant holder and sun screen fixation are very robust and designed for long term use.



**Figure 4** SR25 accelerating sublimation of snow, here shortly after snowfall

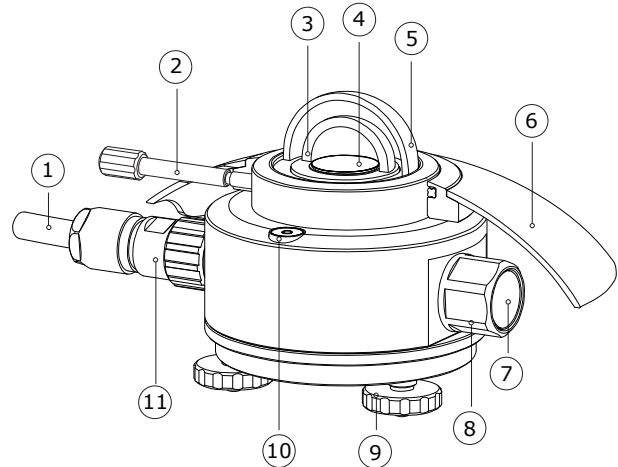

**Figure 5** overview of SR25:

(1) cable, (2) fixation of sun screen, (3) glass inner dome, (4) thermal sensor with black coating, (5) sapphire outer dome, (6) sun screen, (7) humidity indicator, (8) desiccant holder, (9) levelling feet, (10) bubble level, (11) connector

## Uncertainty evaluation

The uncertainty of a measurement under outdoor conditions depends on many factors. Guidelines for uncertainty evaluation according to the "Guide to Expression of Uncertainty in Measurement" (GUM) can be found in our manuals. We provide spreadsheets to assist in the process of uncertainty evaluation of your measurement.

## Standards

Applicable instrument classification standards are ISO 9060 and WMO-No. 8. Calibration is according to ISO 9847. PV related standards are ASTM E2848 and IEC 61724.

## Choosing the right instrument

Pyranometers are subject to classification in three classes according to ISO 9060.

From second class to first class and from first class to secondary standard, the achievable accuracy improves by a factor 2.

Measurement accuracy does not only depend on instrument properties, but also on measurement conditions. A very accurate instrument will quickly underperform without a regular schedule of maintenance.

Our pyranometer selection guide assists you in choosing the right instrument.

Whatever your application is: Hukseflux offers the highest accuracy in every class at the most attractive price level.

## Suggested use

- all situations where ventilated pyranometers are employed
- PV system performance monitoring
- indoor PV testing with solar simulators
- airborne measurements
- diffuse measurements
- environments with dew
- environments with frost

## SR25 features and benefits

- sapphire outer dome: negligible zero offsets
- internal heater: because of dew and frost suppression by heating, better data availability and accuracy than ventilated instruments
- 1.5 W: very low power consumption
- test certificates for temperature response and directional response included: all sensors tested individually for ISO 9060 compliance



**Figure 6** SR25's sapphire outer dome takes solar radiation measurement to the next level

## See also

- SR25-D1 digital secondary standard pyranometer with sapphire outer dome
- the making of SR25 documented
- SR20 secondary standard pyranometer with analogue output, SR20-D1 with digital output
- view our complete range of solar sensors

## SR25 specifications

Measurand	hemispherical solar radiation
ISO classification	secondary standard pyranometer
Zero offset a	1 W/m <sup>2</sup> unventilated to WRR
Calibration traceability	to WRR
Spectral range	285 to 3000 x 10 <sup>-9</sup> m
Sensitivity (nominal)	15 x 10 <sup>-6</sup> V/(W/m <sup>2</sup> )
Rated operating temperature range	-40 to +80 °C
Temperature response	<± 1 % (-10 to +40 °C) <± 0.4 % (-30 to +50 °C) with correction in dataprocessing report included
Temperature response test of individual instrument	report included
Directional response test of individual instrument	report included
Temperature sensor	Pt100 or 10 kΩ thermistor
Heater	1.5 W at 12 VDC
Standard cable length	5 m

## Options

- longer cable, in multiples of 5 metres

## About Hukseflux

Hukseflux Thermal Sensors offers measurement solutions for the most challenging applications. We design and supply sensors as well as test & measuring systems, and offer related services such as engineering and consultancy. With our laboratory facilities, we provide testing services including material characterisation and calibration. Our main area of expertise is measurement of heat transfer and thermal quantities such as solar radiation, heat flux and thermal conductivity. Hukseflux is ISO 9001:2008 certified. Hukseflux sensors, systems and services are offered worldwide via our office in Delft, the Netherlands and local distributors.

Interested in this product?  
E-mail us at: [info@huksefluxusa.com](mailto:info@huksefluxusa.com)

# SR25 secondary standard pyranometer with sapphire outer dome

Nowadays, the best pyranometers are made by Hukseflux Thermal Sensors. This overview of features and benefits of SR25 gives you some of the reasons why! Whatever your application is, Hukseflux offers the highest accuracy in every class at the most attractive price level.



### Best measurement accuracy

- lowest zero offsets
- lowest calibration uncertainty
- best temperature dependence



### Best data availability

- sapphire dome combined with internal heating
  - suppresses dew and frost deposition
  - very low power consumption



### Best connector

- interchangeable cables
- IP67 grade
- for industrial use



### Best desiccant cartridge

- visible indicator of instrument health
  - rugged aluminium design
  - serviceable by user



### Best sun screen

- sealed
- corrosion protection of body
- no dry-cooking of bubble level

### Best paperwork

- full directional response testing
- temperature response testing from -30 to 50 °C
- all ISO required reports included with every individual sensor

